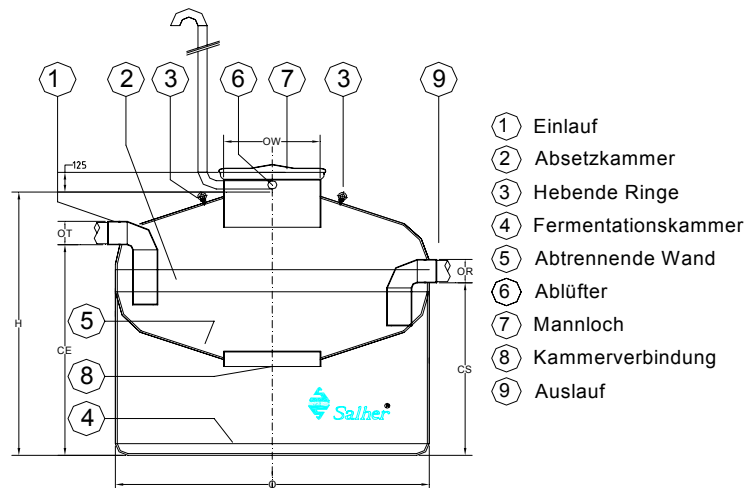

**FERMENTATION-SYSTEM – DER VERTIKALE SEPTISCHE TANK (GROSS)**  
**MODEL: CVC - FS**

- ① Einlauf
- ② Absetzkammer
- ③ Hebende Ringe
- ④ Fermentationskammer
- ⑤ Abtrennende Wand
- ⑥ Ablüfter
- ⑦ Mannloch
- ⑧ Kammerverbindung
- ⑨ Auslauf

EW	Kapazität [L]	Ø [mm]	Länge [mm]	Ø Deckel [mm]	Ø Rohr [mm]	Ø Zulauf [mm]	Ø Ablauf [mm]
10	1.500	1.400	1.340	500	125		
15	2.250	1.400	1.620	500	125		
20	3.000	1.400	2.040	500	125		
25	3.750	1.700	1.820	500	125		
30	4.500	1.700	2.230	500	125		
35	5.250	1.700	2.490	500	125		
40	6.000	2.000	2.120	500	125		
45	6.750	2.000	2.350	500	125		
50	7.500	2.000	2.590	620	160		
60	9.000	2.000	3.060	620	160		
70	10.500	2.500	2.390	620	160		
80	12.000	2.500	2.700	620	160		
90	13.500	2.500	3.000	620	160		
100	15.000	2.500	3.300	620	200		
125	18.750	2.500	4.070	620	200		
150	22.500	2.500	4.830	620	200		
175	26.250	2.500	5.600	620	200		
200	30.000	2.500	6.360	620	250		
225	33.750	3.000	5.070	620	250		
250	37.500	3.000	5.610	620	250		
275	41.250	3.000	6.140	620	250		
300	45.000	3.000	6.670	620	250		
325	48.750	3.000	7.200	620	250		
350	52.500	3.000	7.730	620	250		